

To add additional support to the base of the assembly use bracing struts (not supplied) fastened between the lowest holes on item 67922 and the vehicle chassis.  
Torque fasteners to 160 – 200 Nm.

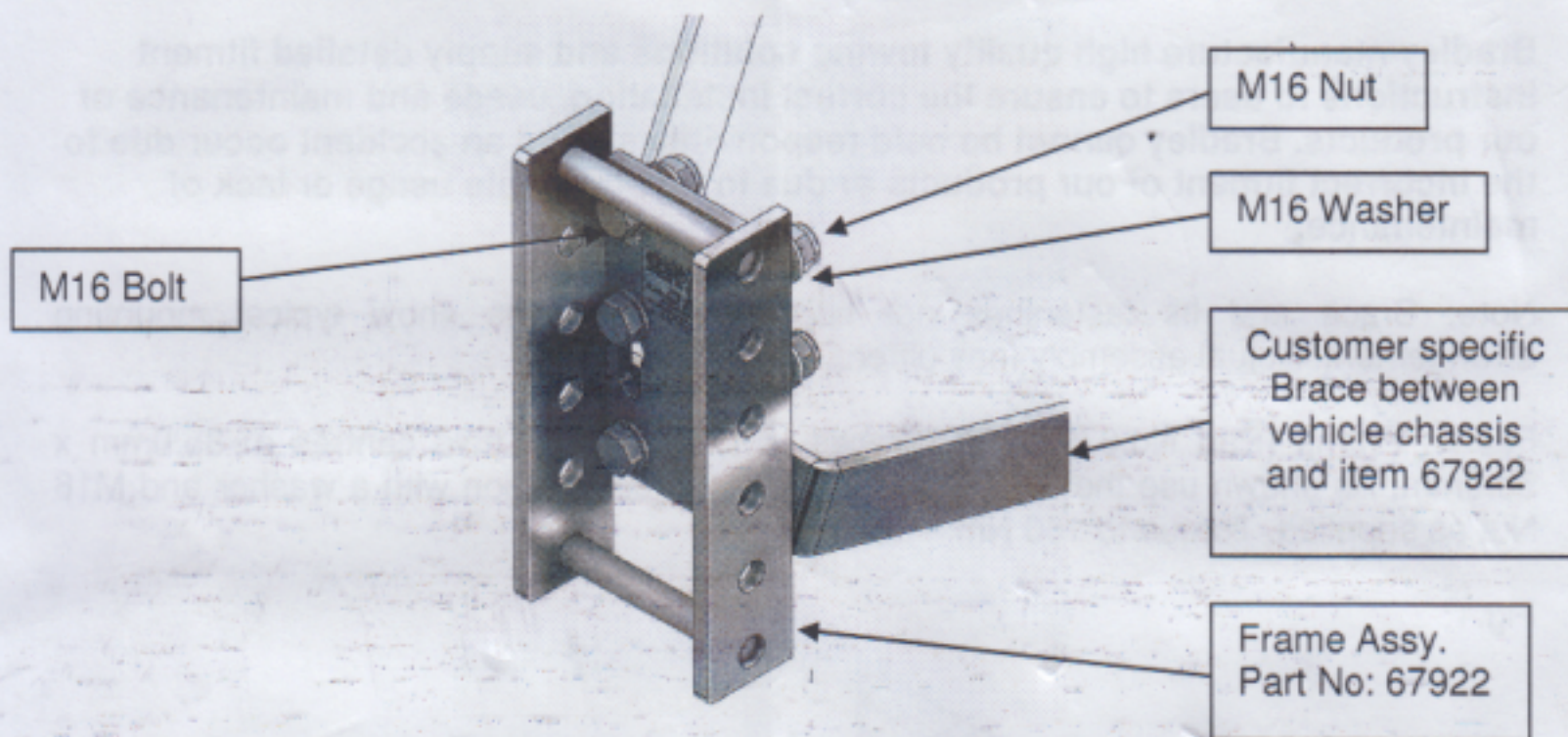

Secure slider (P/N: 68036) to frame using Pin (P/N: 66702) and 'R' - clip (P/N: 102960) as illustrated in Fig. 3. Use two off M16 Bolts, nuts & washers, supplied, to secure your coupling to slider.

Fig. 3:

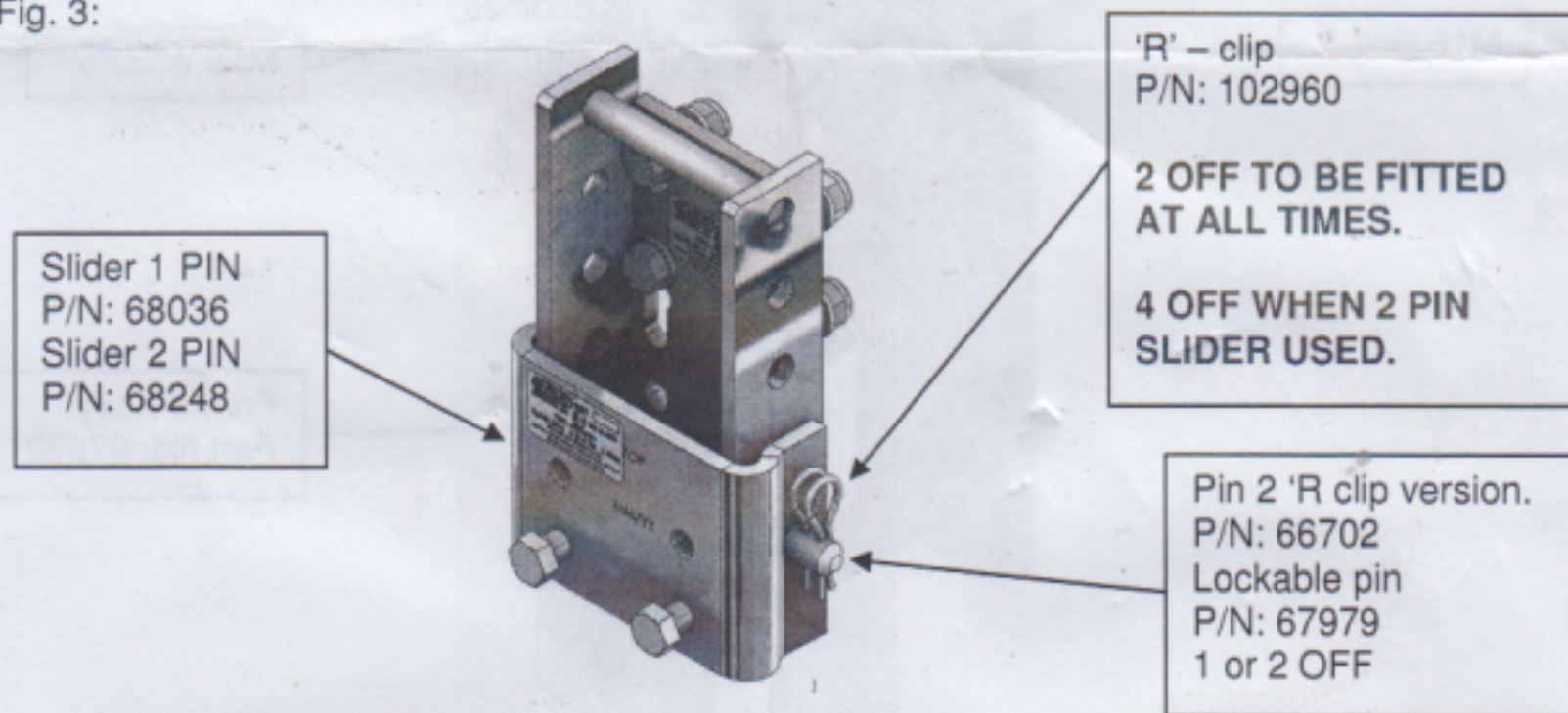

For maximum towing capacity please refer to your vehicle, towbar and coupling manufacturer MGTW data and apply whichever is lower.  
A stabiliser may be used. Please refer to the manufacturer's fitting instruction when fastening either a coupling device or stabiliser to the slider.

Bradley Doublelock Ltd, Victoria Works, Bingley, West Yorkshire, BD16 2NH

Tel: +44 (0)1274 560414 / 516760 Fax: +44 (0)1274 551114

[www.bradleydoublelock.co.uk](http://www.bradleydoublelock.co.uk)